

RJ-225 & RJ-225HD Stationary Compactors

Dimensions and Specifications

Specifications:	RJ-225		RJ-225HD	
Charge Box Capacity				
[Mfr. Rating]	2.0 cu. yd.	1.5 m ³	2.0 cu. yd.	1.5 m ³
[NSWMA Rating]	1.55 cu. yd.	1.18 m ³	1.55 cu. yd.	1.18 m ³
Clear Top Opening (L x W)	40.5" x 60"	1029mm x 1524mm	40.5" x 60"	1029mm x 1524mm
Performance:				
Cycle Time	56 sec.	56 sec.	48 sec.	48 sec.
Total Normal Force	46,700 lbs.	21,183 kg	59,400 lbs.	26,944 kg
Total Maximum Force	55,100 lbs.	24,993 kg	67,900 lbs.	30,799 kg
Normal Ram Face Pressure	26.8 psi	1.85 bar	34.1 psi	? bar
Maximum Ram Face Pressure	31.7 psi	2.19 bar	39 psi	? bar
Ram Penetration	14"	356mm	14"	356mm
Electrical Equipment:				
Electrical Motor 3/60-208/230/460	10 hp	7.5 kw	15 hp	11.2 kw
Electrical Control Voltage	120 VAC	120 VAC	120 VAC	120 VAC
UL® and CUL® listed Panel Box: NEMA Type, All Circuits Fused				
2 Button Controls: Keylock Start/Stop				
Hydraulic Equipment:				
Pump Capacity	13 gpm	49.2 liters/min	13 gpm	49.2 liters/min
Normal Pressure	1,650 psi	114 bar	2,100 psi	145 bar
Maximum Pressure	1,950 psi	134 bar	2,400 psi	166 bar
Hydraulic Cylinder (Bore)	6"	152mm	6"	152mm
Hydraulic Cylinder (Rod)	2.5"	64mm	4"	102mm
Hydraulic Cylinder (Stroke)	56"	1422mm	56"	1422mm
Structural Characteristics:				
Charge Box Sides	1/4"	6.4mm	1/4"	6.4mm
Charge Box Floor	1/2"	12.7mm	1/2"	12.7mm
Ram Face Plate	1/2"	12.7mm	1/2"	12.7mm
Ram Face Size	60" - 29"	1524mm - 737mm	60" - 29"	1524mm - 737mm
Ram Bottom	3/8"	9.5mm	3/8"	9.5mm
Ram Top	3/8"	9.5mm	3/8"	9.5mm
Breaker Bar	8" x 6" x 3/4"	203mm x 152mm x 1.9mm	8" x 6" x 1"	203mm x 152mm x 2.5mm
Weight	5150 lbs.	2336 kg	5,450 lbs.	2472 kg

Compactor Rental and Leasing Programs Available

For detailed specifications, recommendations, or free economic studies comparing various systems, contact Marathon Customer Care at **1-800-633-8974**.



Authorized Dealer:

Stationary and self-contained compactors.

MARATHON
 A DOVER COMPANY
 Marathon Equipment Company
 P.O. Box 1798
 Vernon, AL 35592-1798
 800.633.8974
 www.marathonequipment.com
 NJPA Contract #060612-ESG



Environmental Solutions Group
 A DOVER COMPANY
 www.doveresg.com



Pictures in this literature are illustrative only. Specifications are subject to change without notice in order to accommodate improvements to the equipment. Certified in compliance with ANSI standard Z245.2, applicable OSHA Regulations, and certified under WASTE's Stationary Compactor Certification Program. Products must be used with safe practice and in accordance with said regulations and standards.



You can add the Pandora Remote Monitoring System to many of our most popular compactors. Pandora enables you to measurably reduce your waste management costs. To find out more, contact your Marathon representative today.

Pandora Platform Functionality

Optional on all RJ-225 and RJ-225HD Compactors

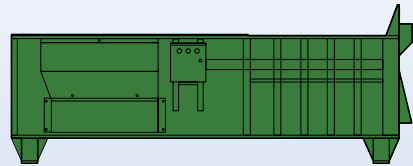

RJ-225

Compactor with PLC and wireless modem

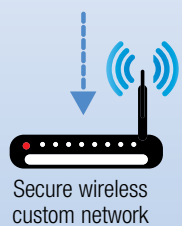

Pandora Server

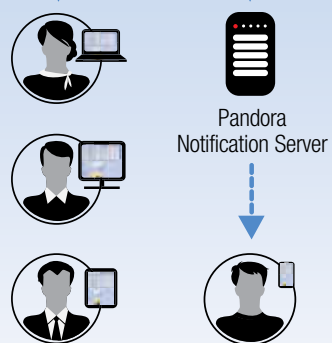

- ✓ Pandora can display daily equipment status on a desktop or mobile PC, tablet, or smart phone
- ✓ Staff can login from any desktop or wireless device
- ✓ Pandora can send notifications to superintendent or directly to haulers



RJ-225 & RJ-225HD Stationary Compactors

Ideally suited for commercial and medium industrial applications

Over 55,000 lbs. of compaction force

Tricon Fullness Assurance System

Multiple options available



RJ-225

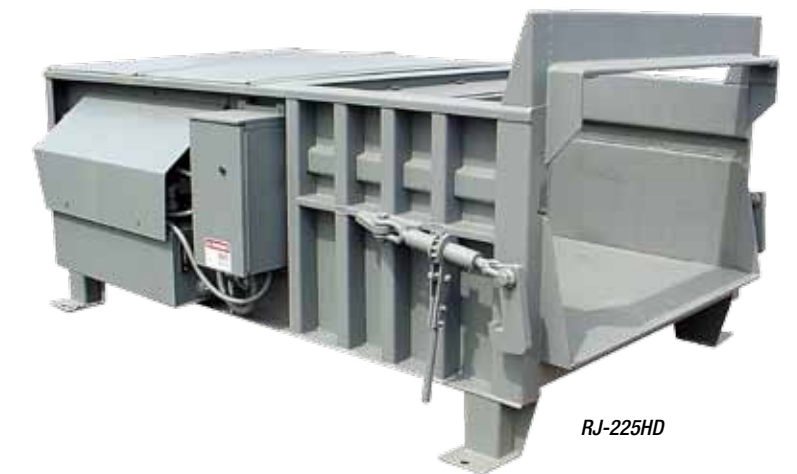

RJ-225HD



Malls

Light industrial and Heavy commercial

Small distribution centers and warehouses

Shopping centers

RJ-225 Compactor

The Ramjet 225 is your best compactor value. Built for reliable performance in commercial and medium industrial situations, it effectively reduces solid waste material to a fraction of its original size. It is attractively priced and features 56-second cycle time and powerful 55,100 lbs. (24.95 kg) maximum compaction force.



RJ-225 Features

- ✔ IEC motor starter
- ✔ Heavier steel in key structural areas for heavy-duty construction: charge box floor and ram face, 1/2-inch (12.7mm) steel; ram top, 3/8-inch (9.52mm) steel; sides, 1/4-inch (6.35mm) steel plate.
- ✔ TEFC (totally enclosed fan cooled) motor
- ✔ Quick release motor mount on the side

mounted power unit for easy servicing and maintenance.

✔ TRICON Fullness Assurance System eliminates all but one limit switch. It also produces better compaction ratios by making the ram dwell against the trash, reducing the "memory" and springback. TRICON offers better cold weather performance and extends the life of the compactor.

RJ-225HD Heavy-Duty Compactor

The Ramjet RJ-225HD is specifically designed for tough waste disposal applications.

Heavy-duty features such as 1/2-inch (12.7mm) steel plate charge box floor over four - 4-inch (102mm) steel channels; 1/2-inch (12.7mm) ram face plate backed with 10-inch (254mm) channels that incorporate T-1



place in high-stress areas; 3/8-inch (9.52mm) ram top supported by eight heavy-duty formed crossmembers; and heavily reinforced charge box sides.

The RJ-225HD is ideally suited for industrial applications such as the disposal of skids and cartons and recycling OCC (old cardboard containers), paper, and similar materials. Electrical components, including the control box assembly, are UL and CUL listed. The 40 1/2-inch (1029mm) x 60-inch (1524mm) charge box is 33-inches (838mm) deep to make disposal fast and easy.

Images shown with optional equipment



Ram Guide System

The packing ram is supported by specially formulated cast iron shoes which ride on replaceable wear strips. This

exclusive design protects the charge box floor from the full force of the packing ram, extending its life and dramatically reducing compaction-robbing friction.

Control Station

The RJ-225 and RJ-225HD feature an advanced, simplified 2-button control system. It is a key-operated, fully automatic and contained in a weatherproof NEMA 4 enclosure. Connected to the power pack with 13-foot (3.96m) of Sealtite®, the controls can be located for operator convenience.



Dimensions

RJ-225

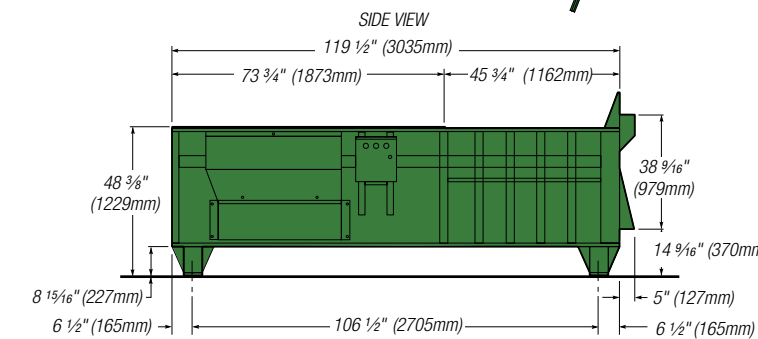
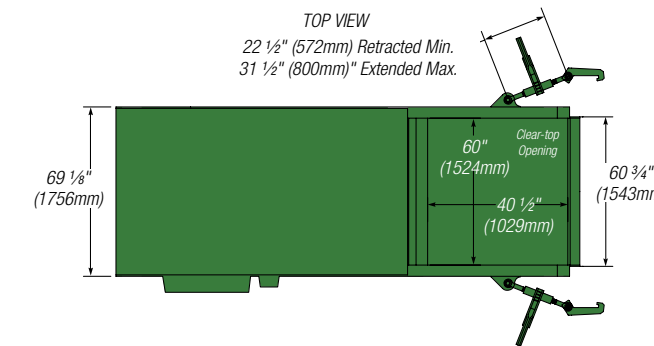
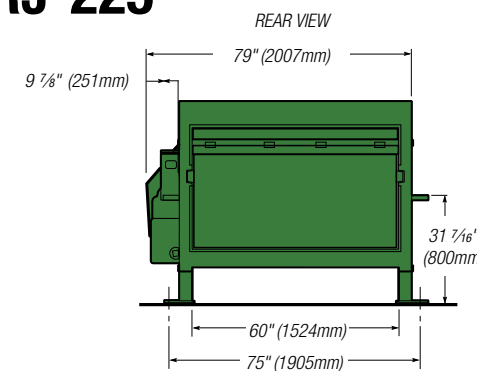

RJ-225HD

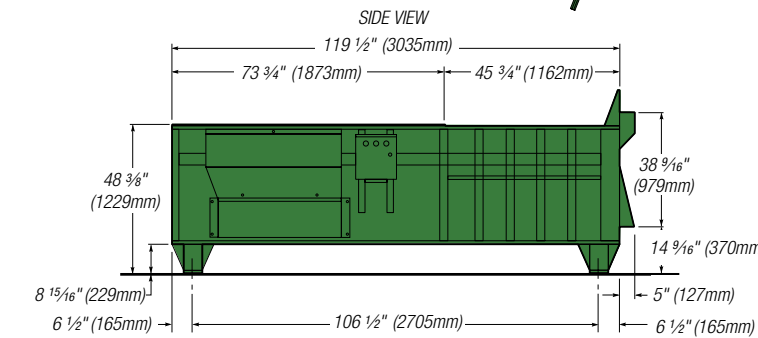
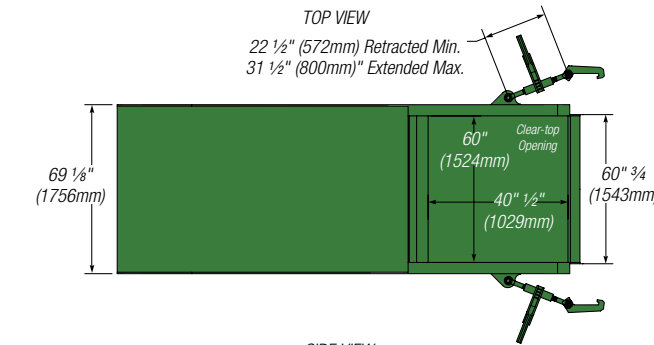
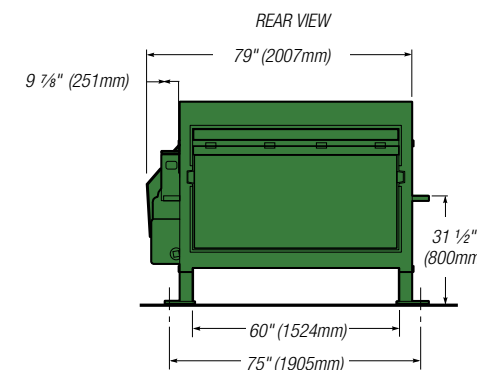

Pandora Remote Monitoring System

The revolutionary Pandora Remote Monitoring System from Marathon enables you to monitor your compaction and baling equipment remotely, right from your desktop or mobile device using integrated wireless communications. The Pandora system combines onsite factory built-in or external add-on hardware with an industry-leading software platform – Pandora Intelligent Networks™ - to give you, real-time compactor and baler data, 24 hours per day, seven days per week.

Pandora gives you the tools to optimize your equipment and measurably reduce your waste management costs. You can eliminate unnecessary pickups, service your equipment to prevent downtime, and substantially reduce your overall carbon footprint.

View the Compactor

- ✔ Check performance
- ✔ Monitor fullness
- ✔ Identify misuse

Manage the Network

- ✔ Automate the scheduling of pickups and service calls
- ✔ Track performance trends
- ✔ Identify and address areas of inefficiency

Stay Connected

- ✔ Receive email or text alerts on your mobile device
- ✔ Communicate important decisions from any location
- ✔ Automatically escalate missed pickups or service call notifications

Repairs

- ✔ Schedule service before costly breakdowns
- ✔ Keep equipment operating at peak efficiency
- ✔ Receive malfunction and online alerts
- ✔ Reduce service and replacement costs

Metrics

- ✔ Create a custom dashboard to view equipment data and analyze operating trends
- ✔ Identify ways to enhance performance

Pickups

- ✔ Automatically notify the hauler when compactors reach their desired fullness level
- ✔ Pay only for necessary pickups