

RJ-275 & RJ-275XHD Stationary Compactors

Dimensions and Specifications

Specifications:	RJ-275		RJ-275XHD	
Charge Box Capacity				
[Mfr. Rating]	2.5 cu. yd.	1.91 m ³	2.5 cu. yd.	1.91 m ³
[NSWMA Rating]	2.05 cu. yd.	1.57 m ³	2.06 cu. yd.	1.58 m ³
Clear Top Opening (L x W)	60" x 54"	1524mm x 1372mm	60" x 52"	1524mm x 1321mm
Performance:				
Cycle Time	60 sec.	60 sec.	52 sec.	52 sec.
Total Normal Force	46,700 lbs.	21,183 kg	80,800 lbs.	36,650 kg
Total Pack-Out Force	55,100 lbs.	24,993 kg	92,400 lbs.	41,913 kg
Normal Ram Face Force	26.8 psi	185 kPa	44.9 psi	310 kPa
Pack-Out Ram Face Force	31.7 psi	219 kPa	51.3 psi	354 kPa
Ram Penetration	13"	330mm	14.5"	368mm
Electrical Equipment:				
Electrical Motor 3/60-208/230/460	10 hp	7.5 kw	15 hp	11 kw
Electrical Control Voltage	120 VAC	120 VAC	120 VAC	120 VAC
UL® and CUL® Listed Panel Box: NEMA Type, All Circuits Fused				
2 Button Controls: Keylock Start/Stop				
Hydraulic Equipment:				
Pump Capacity	13 gpm	49.2 liters/min	13 gpm	49.2 liters/min
Normal Pressure	1,650 psi	114 bar	2,100 psi	145 bar
Maximum Pressure	1,950 psi	134 bar	2,400 psi	165 bar
Hydraulic Cylinder (Bore)	6"	152mm	7"	178mm
Hydraulic Cylinder (Rod)	4"	102mm	4"	102mm
Hydraulic Cylinder (Stroke)	68"	1,727mm	68"	1,727mm
Reservoir Capacity	20 gal.	76 liter	20 gal.	76 liter
Weight	5,875 lbs.	2,665 kg	7,900 lbs.	3,583 kg

Compactor Rental and Leasing Programs Available

For detailed specifications, recommendations, or free economic studies comparing various systems, contact Marathon Customer Care at **1-800-633-8974**.



Stationary and self-contained compactors.

Authorized Dealer:

MARATHON
 A DOVER COMPANY
 Marathon Equipment Company
 P.O. Box 1798
 Vernon, AL 35592-1798
 800.633.8974
 www.marathonequipment.com
 NJPA Contract #060612-ESG



Environmental Solutions Group
 A DOVER COMPANY
 www.doveresg.com



Pictures in this literature are illustrative only. Specifications are subject to change without notice in order to accommodate improvements to the equipment. Certified in compliance with ANSI standard Z245.2, applicable OSHA Regulations, and certified under WASTEC's Stationary Compactor Certification Program. Products must be used with safe practice and in accordance with said regulations and standards.

© 2013 Marathon Equipment Company. All rights reserved. Printed in USA. | SWS-M00105-021313



You can add the Pandora Remote Monitoring System to many of our most popular compactors. Pandora enables you to measurably reduce your waste management costs. To find out more, contact your Marathon representative today.

Pandora Platform Functionality

Optional on all RJ-275 and RJ-275XHD Compactors

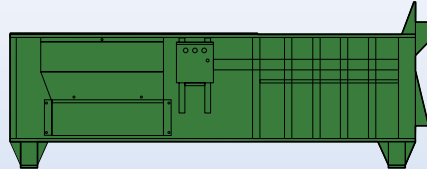

RJ-275

Compactor with PLC and wireless modem

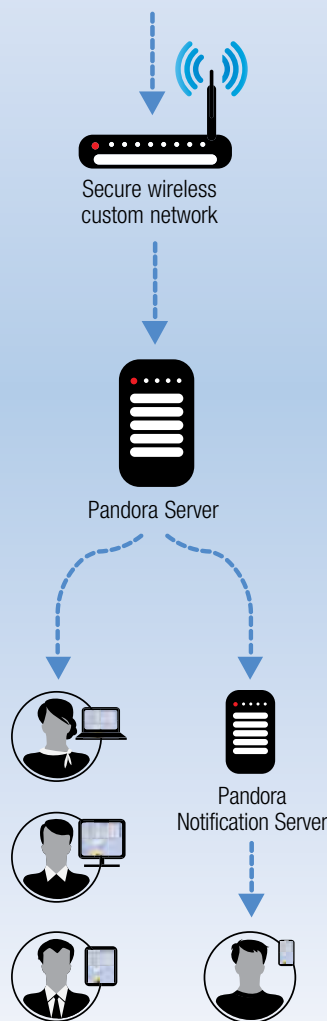

- ✓ Pandora can display daily equipment status on a desktop or mobile PC, tablet, or smart phone
- ✓ Staff can login from any desktop or wireless device
- ✓ Pandora can send notifications to superintendent or directly to haulers



RJ-275 & RJ-275XHD Stationary Compactors

Compaction for commercial and industrial applications

Side-mounted and remote power units simplify operation and maintenance

Up to 92,400 pounds (41.73 kg) of force

Heavy-duty construction for durability and long life



RJ-275



RJ-275XHD



Malls

Light industrial and Heavy commercial

Small distribution centers and warehouses

Shopping centers

RJ-275 Compactor

Marathon's Ramjet RJ-275 is your best 2.5 cubic yard capacity compactor value. Built for reliable performance in commercial and medium industrial applications, it effectively reduces solid waste material to a fraction of its original size. It features a 60-second cycle time and a powerful 55,100 pounds (24,993 kg) of compaction force.



Engineered for Durability

The RJ-275 is stress-engineered for durability. This means the strength is where it belongs—like the half-inch charge box floor reinforced with five heavy-duty steel channels, the half-inch plate ram face backed with 10-inch (254mm) plus 6-inch (152mm) structural channels, and the extra rugged reinforced sides.

RJ-275XHD Hi-Force Heavy-Duty Compactor

Marathon's Ramjet RJ-275XHD produces more than 92,400 pounds (41.73 kg) of force assuring top performance in heavy commercial and industrial applications. The RJ-275XHD is unique to other compactors in its class, providing a large 60-inch wide (1524mm) by 52-inch (1321mm) long clear top opening and a 33-inch (838mm) deep charge box – a convenient feature at peak loading times or when compacting bulky items.



Heavy-Duty Design

The RJ-275XHD is stress-engineered for durability. This means the strength is where it belongs—like the half-inch charge box floor reinforced with heavy-duty steel channels, 3/4-inch steel plate ram face backed with structural channels, and extra rugged reinforced sides.

- ✓ Multi-cycle timer, dual controls, ozone odor control system, hoppers, and many other options are also available as well as a full-line of compaction containers.
- ✓ Chutes can be constructed to meet your specifications and needs. They reduce the risk of pilferage of valuable merchandise or tools by eliminating a person's ability to hide items in the trash in order to recover them later from the waste receptacle.

Images shown with optional equipment



Ram Guide System

The packing ram is supported by specially formulated cast iron shoes which ride on replaceable wear strips. This

exclusive design protects the charge box floor from the full force of the packing ram, extending its life and dramatically reducing compaction-robbing friction.

Control Station

The RJ-275 and RJ-275XHD feature an advanced, simplified 2-button control system. It is a key-operated, fully automatic and contained in a weatherproof NEMA 4 enclosure. Connected to the power pack with 13-foot (3.96m) of Sealtite®, the controls can be located for operator convenience.



Dimensions

RJ-275

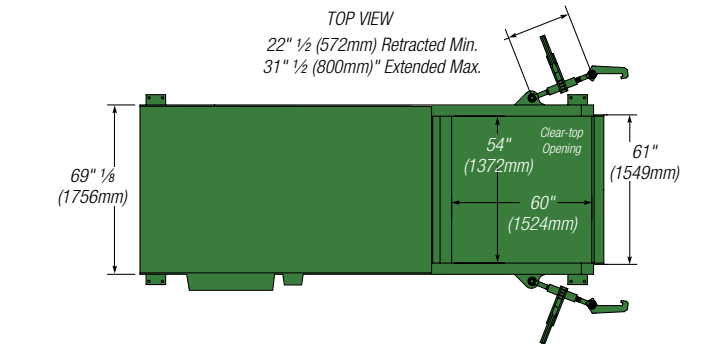
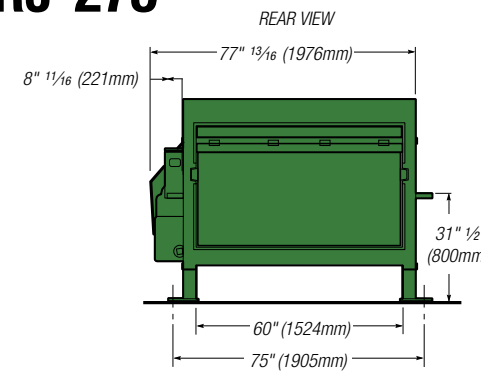

RJ-275XHD

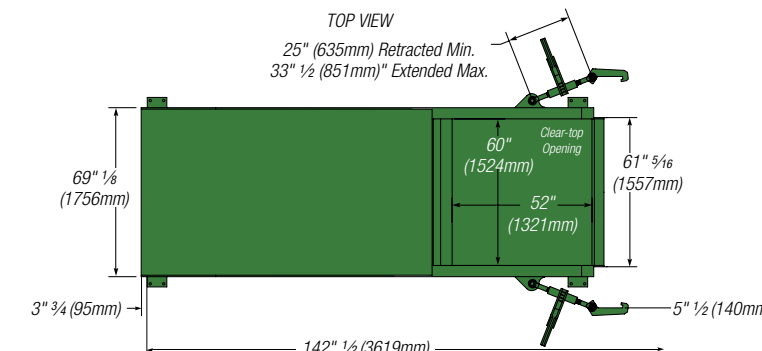
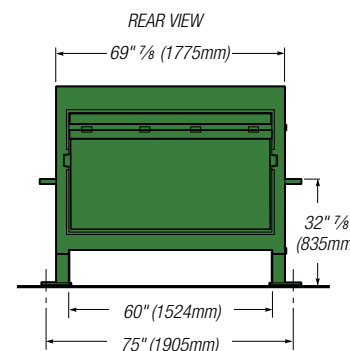

Pandora Remote Monitoring System

The revolutionary Pandora Remote Monitoring System from Marathon enables you to monitor your compaction and baling equipment remotely, right from your desktop or mobile device using integrated wireless communications. The Pandora system combines onsite factory built-in or external add-on hardware with an industry-leading software platform – Pandora Intelligent Networks™ - to give you, real-time compactor and baler data, 24 hours per day, seven days per week.

Pandora gives you the tools to optimize your equipment and measurably reduce your waste management costs. You can eliminate unnecessary pickups, service your equipment to prevent downtime, and substantially reduce your overall carbon footprint.

View the Compactor

- ✓ Check performance
- ✓ Monitor fullness
- ✓ Identify misuse

Manage the Network

- ✓ Automate the scheduling of pickups and service calls
- ✓ Track performance trends
- ✓ Identify and address areas of inefficiency

Stay Connected

- ✓ Receive email or text alerts on your mobile device
- ✓ Communicate important decisions from any location
- ✓ Automatically escalate missed pickups or service call notifications

Repairs

- ✓ Schedule service before costly breakdowns
- ✓ Keep equipment operating at peak efficiency
- ✓ Receive malfunction and online alerts
- ✓ Reduce service and replacement costs

Metrics

- ✓ Create a custom dashboard to view equipment data and analyze operating trends
- ✓ Identify ways to enhance performance

Pickups

- ✓ Automatically notify the hauler when compactors reach their desired fullness level
- ✓ Pay only for necessary pickups